

# Instantaneous Torque Control of Small Inductance Brushless DC Motor

M.Ragul Kumar

**Abstract**— This method deals with an accurate control process of BLDC motor by reducing torque ripple. The reduction technique of torque ripple is achieved by suppressed error between the command and estimated torques. The conduction and controller control the torques instantaneously. The instant control achieves with the torque controller and torque estimate. The PI controller and back EMF has feed forward controller method controls the high torques in conduction region and outgoing torque ripple are reduced in commutation regions. To avoid ripple high frequency to be set as during commutation. To regulate BUCK BOOST Converter during commutation output of commutation ripples controller has used. The sensorless control applied to detect position of the rotor through optimizing current and reducing torque pulsation. This is the advanced method of Field Oriented Control (FOC) of BLDC motor for non sinusoidal back EMF rotor speed achieved by Simulink. The Back EMF feed forward control is applied to control torque with current dynamics.

**Index Terms**— Brushless DC motor (BLDC), FOC, Back EMF, BUCK BOOST Converter, PI controller, sensorless control, instantaneous torque control, torque ripple reduction.

## I. INTRODUCTION

Brushless DC motor is extensively used high-performance applications, which having distinct advantage such as high power density, high efficient methodology, large torques to inertia and simplicity in their control. The torque smoothness is essentially for high performance motions control application and obtains an accurate and ripple free instantaneous torque is great importance for BLDC motor.

The torque mainly include cogging torques, reluctance torque, and mutual torque, among which the cogging torques is induced by stator slots interact with the rotor magnetic fields and is independent of stator current excitation method. And, reluctance torque has caused by their variations in phase inductance with respect to this position, while mutual torque is created by mutual coupling between the stator winding currents and rotor magnetic field. From these machine design perspectives, it is of great interest to find the fundamental components of the total flux linkages.

Clearly, it is desirable to minimize the torque ripples in a brushless dc (BLDC) drive, since it may be result in unacceptable speed ripple, vibrations, and acoustic noise. Ideally, a BLDC motor, with a trapezoidal back-electromotive-force (EMF) waveform whose amplitude is constant over  $120^\circ$  elec., will produce ripple-free torque when supplied with rectangular  $120^\circ$  electrical phase current waveforms. However, in a practical BLDC drive, significant

torque pulsations may arise due to the back-EMF waveform. A sensor-less FOC scheme has been applied to BLDC motor with non-sinusoidal Back EMF [1].

Torque ripples is usually considered to one of the main drawbacks of BLDC drives, compared to brushless ac (BLDC) drives with sinusoidal Back EMF; it could be eliminated at low speed by employing current control based on direct current sensing method[2]. The control of BLDC motors can be done in sensor or sensorless mode, but to reduce overall cost of actuating devices, sensor-less control techniques are normally used. The advantage of sensor-less BLDC motor control is that the sensing part can be omitted, and thus overall costs can be considerably reduced [3].

The technique utilize the dependence of inductances on rotor position in interior permanent magnet machines to produce position and velocity estimate both for field orientation and for all motion control of the drives. The sensed currents are then processed with a heterodyning techniques that produces a signal that is approximately proportional to the difference between the actual rotor position and an estimated rotor position [4].

Recently some approach method has compensate the misalignment effects of Hall sensors have been introduced. Since its main algorithm is based on the average speed, the performance may degrade at a variable speed operations the repetitive control techniques is applied to the torque ripple reduction in high performance PMSM drives, where the axis current references has been modified. More specifically, the repetitive controller is merged with a conventional PI controller, where as the PI control dominates during transients and large signal dynamics, while the repetitive control ensured the compensation of the remaining errors so as to achieve a near perfect tracking of a periodic current reference signal [7].

Some studies use current sensors to feedback current signals for commutation control. This method detected the dc link current to determine the commutation instants during the start up process. As the current magnitude is greater than the specified value, commutation occurs. However, current spikes caused by commutation and how to determine this specified current value are some of the practical concerns [8]. However, in order to calculate the slope of current ripple, the phase current should be detected more than twice for each chop on or chop off period. Therefore, high-speed A/D converter is required for current sampling.

Several approaches to zero-crossing detection of back EMF have been proposed. These methods include using position sensors, and current feedback via the resistor connected in

series with dc link voltage. A novel Fault Tolerance (FT) ripple free torque controller for BLDC motors operating under a single phase. Multiple failures can be also recovered for motors with four or more phases [9]. The phase current and torque ripples are severe for BLDCM when three phase inverter is modulated. Here the torque ripple reduction method has been proposed by adding buck converter in the front of three phase inverter. Also the torque ripple in non commutation region is eliminated effectively. Torque ripples due to phase current commutation is reduced in proposed system. Torque ripples reduced by optimizing duty ratio of the active voltage vectors.

Hybrid two and three phase switching mode is employed during commutations, this ripples are suppressed by controlling error between command and estimated torque. It is mainly consists of a torque estimator and torque controller. System configurations high precision instantaneous torque estimator is performed with the help of line to line back emf acquirement, and hall sensor positions calibration & compensation. Instantaneous torque controller accurately controls the torque through conduction and commutation region controller. High torque in the conduction region is achieved by means of PI controller, asymmetry compensation function, and Back EMF feed forward control. The torque ripples in commutation is reduced by controlling their outgoing phase [10].

## II. TORQUE CONTROL

The speed to torque relations of BLDC motors, there are two torque parameters used to define a BLDC motor, peak torque (TP) and rated torque (TR). During continuous operations, the motor can be loaded up to the rated torque. In a BLDC motor, the torque remains constant for a speed range up to the rated speed. The motor can be run up to the maximum speed, which can be up to 150% of the rated speed, but the torque starts dropping off. The back-EMF constant is to back-drive your motor with another motor and measure the voltage that is generated on an oscilloscope. Then measure the peak voltage of that wave form and divide that by the speed that you are back-driving the motor.

The units for torque constant (Kt) and back emf constant (Ke) are equivalent. The units for Kt are  $N \cdot m/A$ . If you expand that out to SI base units, you get  $N \cdot m/A = kg \cdot m^2/A \cdot s^2$ . The voltage in SI base units,

$$V = \frac{kg \cdot m^2}{A \cdot s^3}$$

If divide by  $rad/s$ , it end up with the same units as the units for Kt.

$$\frac{V}{\frac{rad}{sec}} = \frac{kg \cdot m^2}{A \cdot s^2}$$

The units of  $Kt$  and  $Ke$  are equivalent. This equivalence hold between the torque constant and Back EMF constant the "per phase" constants. The "per phase" constants are not usually on a motor datasheet. The overall torques relate to the current, not with the per phase relationships.  $Ke=Kt$  (line-to-

line) in brushless motor with an ideal trapezoidal back emf. For a motor with an ideal sinusoidal back-emf, the relationship is  $Ke= 3\sqrt{2} \cdot Kt$ . In reality, brushless motors can't be made to have either ideal trapezoidal or ideal sinusoidal Back-EMFs.

### A. Field Oriented Control

FOC is possible to control directly the stator flux and the torque by selecting the appropriate inverter state. This control method does not need coordinate transforms, voltage modulator block, as well as other controllers such as PI for flux and torque. Even this method is better than the vector method because its torque response time minimum. The way to impose the required stator flux is by means of choosing the most suitable Voltage Source Inverter state.

The reference values for the flux stator modulus and the torque are compared with the actual values, and the resulting error values are fed into the two-level and three-level hysteresis blocks respectively. The outputs of the stator flux error and torque error hysteresis blocks, together with the position of the stator flux are used as inputs of the look up table. The position of the stator flux is divided into six different sectors..

### B. Sensorless Field Oriented Control

Field Oriented control (FOC) can directly control the inverter states in order to reduce the torque error within the prefixed band limit FOC of brushless dc drive with trapezoidal back-EMF is presented in this paper. Using the rotor flux vector position in alpha - beta axis stationary reference frame and torque error, the proper switching pattern can be selected to control the generated torque and reducing commutation torque ripple. Sliding mode observer, which is robust to parameter uncertainties can be used to estimate the back-EMF and the generated torque.

The rotor flux vector position estimation and its novel modifier can be achieved using a rotor flux observer. This estimated back-EMF is used to deduce the rotor position and the angular velocity of the rotor. And instantaneous electromagnetic torque can be calculated by the product of back-EMF and current. To overcome these problems, instead of using position sensors, the sensorless method has been developed to estimate the position and velocity of the rotor from the estimate of phase-to-phase back-EMF. The proposed sensorless method is easy to design and has robustness against design parameters.

Transforming the state equation of BLDC motor in  $\alpha$ - $\beta$  stationary reference frame can be written as:

$$v_{s\alpha} = R_s i_{s\alpha} + L_s \frac{di_{s\alpha}}{dt} + e_{\alpha}$$

$$v_{s\beta} = R_s i_{s\beta} + L_s \frac{di_{s\beta}}{dt} + e_{\beta}$$

Where  $\alpha_{sv}$ ,  $\beta_{sv}$ ,  $\alpha_{si}$ ,  $\beta_{si}$ ,  $\alpha_e$ ,  $\beta_e$  are the stator voltage, stator current and Back-EMF respectively in the  $\alpha$ - $\beta$  stationary reference frame. Electromagnetic torque for DTC can be expressed as:

$$T_e = \frac{3p}{4} \left[ \frac{d\psi_{r\alpha}}{d\theta_e} i_{s\alpha} + \frac{d\psi_{r\beta}}{d\theta_e} i_{s\beta} \right]$$

Where  $\alpha_{vr}$  and  $\beta_{vr}$  are the  $\alpha$ - $\beta$  axis rotor flux vector components,  $p$  is the no. of poles and  $\theta_e$  is the rotor electrical angle. The differential form of the rotor flux components respect to  $\theta_e$  can be derived from the ratio of the back-EMF to the electrical angular velocity  $\omega_e$ . i.e.,

$$\frac{d\psi_{r\alpha}}{d\theta_e} = \frac{d\psi_{r\alpha}}{dt} \frac{dt}{d\theta_e} = \frac{1}{\omega_e} \frac{d\psi_{r\alpha}}{dt} = \frac{e_\alpha}{\omega_e}$$

$$\frac{d\psi_{r\beta}}{d\theta_e} = \frac{d\psi_{r\beta}}{dt} \frac{dt}{d\theta_e} = \frac{1}{\omega_e} \frac{d\psi_{r\beta}}{dt} = \frac{e_\beta}{\omega_e}$$

$$\omega_e = \frac{d\theta_e}{dt}$$

Where

Then the electromagnetic torque can be written as,

$$T_e = \frac{3p}{4} \left[ \frac{e_\alpha}{\omega_e} i_{s\alpha} + \frac{e_\beta}{\omega_e} i_{s\beta} \right]$$

There is a possibility to control the stator flux amplitude without commutation issue; therefore, flux-weakening and sensor-less operations that involve Back EMF estimation can easily be performed. Direct torque control has some benefits such as faster torque response and reduced torque ripple for driving the Brushless DC motors to estimate the Back-EMF and generate the torque. It is employed to estimate the non-sinusoidal Back-EMF waveform in a Brushless DC motor using only the measurements of the stator currents.

### III. IMPLEMENTATION OF INSTANTANEOUS CONTROL

Instantaneous torque control would in principle permit the fastest possible response and the elimination of torque ripple, along with many other advantages not possible with conventional control algorithms, most of which are set up to control a time-averaged torque.

#### A. Torque Controller

In the instantaneous torque control, torque is regulated by a controlling the instantaneous phase currents. The reference torque is converted to equivalent reference phase currents so that be tracked in the inner current control loops. By using the phase current profiling techniques, optimal phase torque corresponding to torque sharing functions can be generated, ultimately, torque ripples can be minimized. Various methods of torque ripple-minimization using instantaneous torque control have been successively proposed in the last three decade. However, torque-to-current conversion in BLDC is complex and becomes non-trivial due to their nonlinear relationship.

Analytical expression of such conversion is complicated and leads to intensive on-line computation. On the other hand, the current profiles can be pre-calculated and pre-stored in the

controller memory. Yet, this method requires large amount of on-line memory space. Concepts of instantaneous torque control for BLDC have been developed to overcome the torque ripple drawback. The main of instantaneous torque control characteristics are: the instantaneous torque (which can be estimated from motor terminal quantities) is considered directly as a control variable, torque-to-current conversion and closed-loop control of phase currents are no longer required. As the instantaneous torque is considered directly as a control variable, instantaneous torque control encounters the torque error instantaneously with fast dynamic response and effectively minimizes the inherent torque ripple. The Instantaneous torque control scheme also eliminates the use of current controllers.

**PI Controller:** Due to simple control structure, Easy of design and inexpensive cost the conventional proportional-integral (PI) controller is most widely used in the industry. More than 90% of the control loops were of the PI types. As the formulas of PI controller are very simple and can be easily adopted by various controlled plant. PI controller helps to correct the error between the reference variable and the actual variable. So, that the system can adjust the process accordingly, the general structure of PI controller is given below.

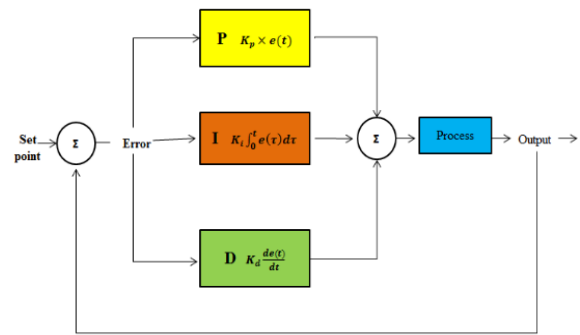

Fig. 1: Structure of PID Controller

For PID control the actuating signal consists of proportional error signal added with derivative and integral of the error signal. The transfer function for the above block diagram i.e. for PID controller is given as,

$$G_{PID} = k_p \left( 1 + s k_d + \frac{k_i}{s} \right)$$

Where, 'K<sub>p</sub>' can be represented as proportionality gain, and 'K<sub>i</sub>' as the integral gain constant. The 'n' proportional control the actuating signal for the control action in control system is proportional to the error signal. The error signal is being the difference between the reference input signal and the feedback signal obtained from the output.

For integral control action the actuating signal consists of proportional-error signal added with integral of the error signal. By the help of an integrator, it reduces the steady state errors through low frequency compensation. By the help of this integral term the actual variable will track the reference variable more quickly. As the integral of the error is used in

actuating signal and as such if the error varies with time, then in that case the integral control reduces the error.

**Back EMF Feed forward control:** The sensor-less speed and position estimation gets divided into two basic which is Sensing or measurement of back-emf from armature terminals and Back-emf observer based on mathematical equations describing motor behavior. A classical example of back-emf sensing based algorithm is 120 degree commutation or trapezoidal control of BLDC motor in which back-emf of non-energized phase is measured for rotor position. This helps to efficiently commutate the motor. The back-emf voltage is calculated indirectly by passing the error between actual measured current and estimated current through PI controller. As true with most sensorless schemes, the presented back-emf observer scheme is also sensitive to motor parameter variation especially to armature resistance. The unbalance ripples are reduced by the proposed asymmetry compensation function and the disturbance ripple created by the back EMF is compensated by feedforward control. Second, the disturbance torque has been observed and compensated through the improved disturbance torque controller whose compensation coefficient is obtained by line-to-line back EMF coefficient estimation.

### B. Torque Estimator

The methodology for detecting absolute position of a BLDC motor using inexpensive analog Hall sensors and allow computation time algorithm to extract position information. Further, this algorithm can be implemented in tandem with simple block commutation, sinusoidal commutation, or direct torque control.

**Hall Sensor:** The main components of the method consist of mounting the sensors in a regular pattern around the motor. One sensor is required per coil.

The sensors are simply measures field strength in a linear axis nearly orthogonal to the coil field. This can be verified theoretically and experimentally. The other implication of this is that the orientation of the Hall Effect sensors relative to the coils and rotor magnets must be carefully determined in order to avoid interference from the time-varying magnetic field generated in the coils. The reluctance of the air is far higher than the reluctance of the motor components, so most of the flux field density due to coil currents remains within the motor. By measuring the analog Hall sensor signal directly, a high resolution rotor position can be extracted from that data. The notion of extracting an angular position from sinusoidal waveforms in general is not new. The concept is that of an older technology – the resolver. However, the present application differs in that the sensor and actuator are integrated and the measurement repeats with every electrical cycle.

**Line-to-line Back EMF:** To eliminate the low-frequency torque oscillations, two actual and easily available line-to-line back EMF constants ( $k_{ba}$  and  $k_{ca}$ ) according to electrical rotor position are obtained offline and converted to the dq frame equivalents. Coordinate transformations are done by the new

line-to-line transformation that forms a  $2 \times 2$  matrix instead of the conventional  $2 \times 3$  matrix. Therefore, rather than three line-to-neutral back EMF waveforms, which are not directly available in the motor easily accessible two line-to-line back EMF constants ( $k_{ba}(\theta_{re})$  and  $k_{ca}(\theta_{re})$ ) are obtained offline and converted to the dq frame equivalents ( $k_d(\theta_{re})$  and  $k_q(\theta_{re})$ ). Then, they are stored in a look-up table for the torque estimation. The electrical rotor position is estimate during winding inductance and stationary reference frame stator flux linkages and currents.

## IV. SIMULATION RESULTS

The simulation was performed with conventional six switches fed BLDC motor. In order to get 120° square wave phase currents, two switches are turned on at a time. The hall sensors mounted on the motor shaft gives the information of rotor position. The parameters of the BLDC motor used for simulation are listed in table below.

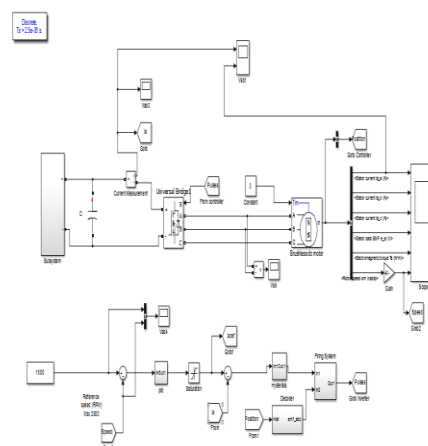

Fig.2 Simulation circuit Diagram

TABLE I - Parameters of the BLDC motor

Table.1 Motor Paramaters

Motor parameters	Motor characteristics Values(units)
Terminal resistance	0.323 Ω
Terminal inductance	0.389 mH
Voltage constant	6.99 V/ k rpm
Electrical time constant	1.205 m-secs
Rotor Inertia Jm	0.142e-3 Kg.m2
No load speed	3434 rpm
No load current	1.24 A
Rated Power	123W
Number of poles	8
Number of phases	3

The output of BUCK BOOST converter waveform is shown below. In order to validate the performance of the brushless dc motor with proposed dc to dc BUCK converter, a simulation model is developed. The simulation is performed with MATLAB simulink.

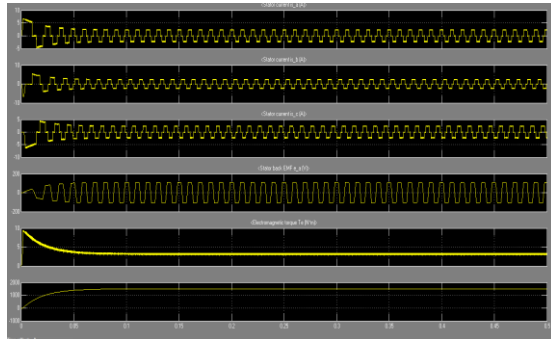

Figure 3: simulation output

Some applications, such as an automobile (Windscreen wiper), require the motor to have a fairly constant speed for different loads. DC motors such as shunt and compound work reasonably well in these applications, but a BLDC with a PI controller improves the performance. The speed vs. torque and 10 show that the speed remains virtually constant across the torque range. These curves are more similar to a separately excited DC motor, but they are actually much better because of the feedback control.

## V. CONCLUSION

The Various sensorless control techniques are being introduced and researched in order to replace the use of sensor control techniques in a BLDC system. By doing this, the cost of the system can be reduced and BLDC can be more affordable. Torque ripples due to phase current commutation is reduced by optimizing duty ratio of the active voltage vectors and by controlling error b/w command and estimated torque. Finally the instantaneous torque estimated with the help of line-to-line Back EMF acquirement , and hall sensor position calibration & compensation. With the help of PID controller and Back EMF feed forward control High torque in the conduction region is achieved. By controlling the outgoing phase current the torque ripple in commutation are reduced. This method of torque ripple reduction is analyzed and validated using MATLAB simulation results.

## REFERENCES

- [1] Jiancheng Fang, Member, IEEE, Xinxu Zhou, and Gang Liu, "Instantaneous Torque Control of Small Inductance Brushless DC Motor", IEEE transactions on power electronics, vol. 27, no. 12, december 2012.
- [2] N. Milivojevic, M. Krishnamurthy, A. Emadi, and I. Stamenkovic, "Theory and implementation of a simple digital control strategy for brushless DC generators," IEEE Trans. Power Electron., vol. 26, no. 11, pp. 3345–3356, Nov. 2011.
- [3] Y. S. Lai and Y. K. Lin, "A unified approach to zero-crossing point detection of back EMF for brushless DC motor drives without current and hall sensors," IEEE Trans. Power Electron., vol. 26, no. 6, pp. 1704–1713, Jun. 2011.

- [4] R. J. Wang, M. J. Kamper, K. V. Westhuizen, and J. F. Gieras, "Optimal design of a coreless stator axial flux permanent-magnet generator," IEEE Trans. Magn., vol. 41, no. 1, pp. 55–64, Jan. 2005.
- [5] M. Ooshima, S. Kitazawa, A. Chiba, T. Fukao, and D. G. Dorrell, "Design and analyses of a coreless-stator-type bearingless motor/generator for clean energy generation and storage systems," IEEE Trans. Magn., vol. 42, no. 10, pp. 3461–3463, Oct. 2006.
- [6] C. C. Hwang, P. L. Li, F. C. Chuang, C. T. Liu, and K. H. Huang, "Optimization for reduction of torque ripple in an axial flux permanent magnet machine," IEEE Trans. Magn., vol. 45, no. 3, pp. 1760–1763, Mar. 2009.
- [7] S. J. Park, H.W. Park, M. H. Lee, and F. Harashima, "A new approach for minimum-torque-ripple maximum-efficiency control of BLDC motor," IEEE Trans. Ind. Electron., vol. 47, no. 1, pp. 109–114, Feb. 2000.
- [8] P. Mattavelli, L. Tubiana, and M. Zigliotto, "Torque-ripple reduction in PM synchronous motor drives using repetitive current control," IEEE Trans. Power Electron., vol. 20, no. 6, pp. 1423–1431, Nov. 2005.
- [9] F. Aghili, "Adaptive reshaping of excitation currents for accurate torque control of brushless motors," IEEE Trans. Contr. Syst. Technol., vol. 16, no. 2, pp. 356–364, Mar. 2008.
- [11] T. M. Jahns and W. L. Soong, "Pulsating torque minimization techniques for permanent magnet AC motor drives-a review," IEEE Trans. Ind. Electron., vol. 43, no. 2, pp. 321–330, Apr. 1996.

[1]